

**BOULEVARD DES PRODUCTIONS, STRASBOURG**

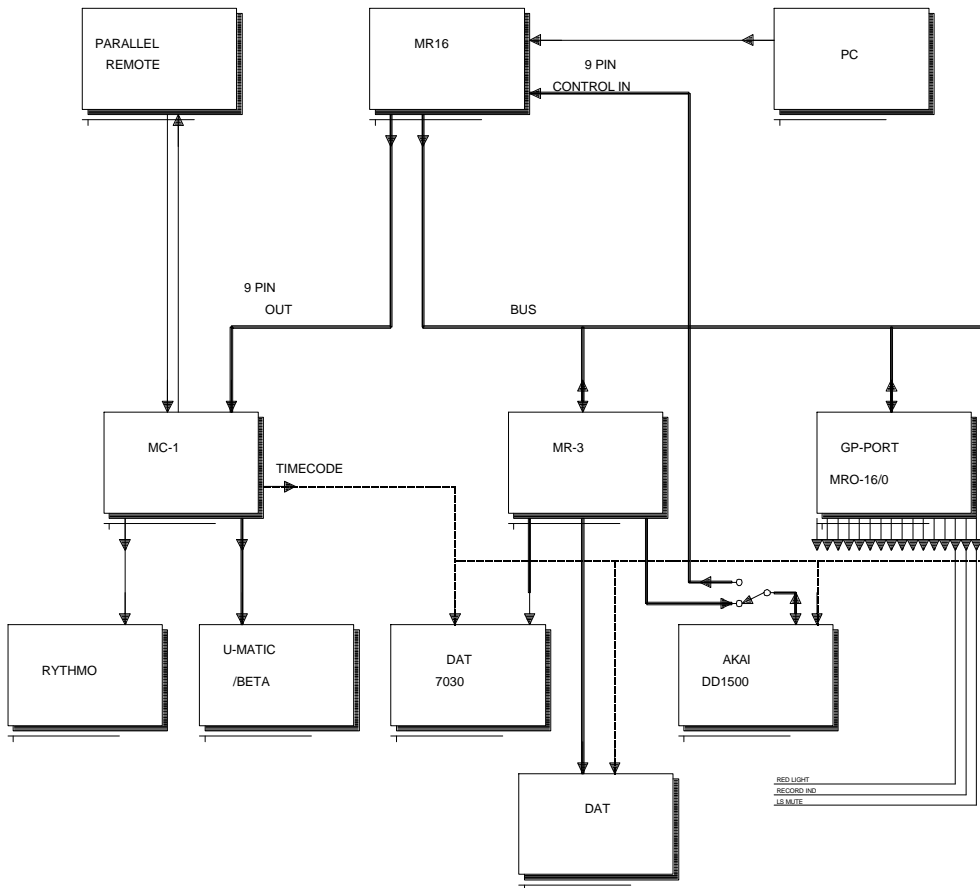

THE SYSTEM MAY BE CONTROLLED FROM THE PARALLEL REMOTE, MR-16 OR THE DD1500. THE MR-16 PROVIDES 16 RECORD READY SWITCHES THAT MAY BE SWITCHED TO A MAXIMUM OF 64 CHANNELS

**EXPANSION**

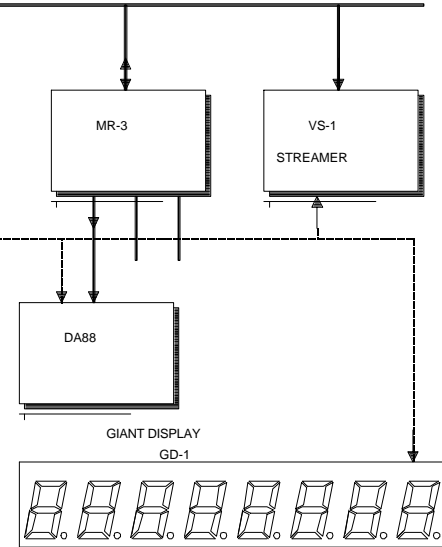

NOTE: ALL UNITS REQUIRE VIDEO SYNC!

37 WAY PARALLEL		TIMECODE		CB ELECTRONICS	
BI-PHASE		9-PIN		LONDONSIDE, LANDS END HOUSE, BEGGARS HILL ROAD, CHARVEL, READING RG10 5UD	
Rev	B	Document Number		BYD-BLK	REV
Date	February 13, 1998	Sheet	of		